



PROFRUIT
-MACHINERY-



**Fruit, berry & vegetable juice
production machinery**

Belt Press POWERPRESS 350

Belt Press POWERPRESS 350

POWERPRESS are designed for pressing fruit and vegetable mass. Fruit mass is placed on the tape which presses it against cylinders. The obtained juice flows in the collection trays under the press. Pressing is continuous.

Capacity: POWERPRESS 350 – 350 kg/h.

- The most evolutionary feature of our Belt press POWERPRESS line is integrated pump and juice collection tank into the press itself. That means that you save money and do not need an additional juice collection tank and pump which otherwise would use much space and money.
- There is a filtration sieve integrated into the juice collection tank, so the juice is being filtrated even during the pressing stage providing cleaner and more pure product.
- Entirely made of stainless steel.
- Mounted on adjustable feet.
- The press functions automatically. When the tank of the mass is full, all other machines which come before BP turns off automatically. When the juice tank is full, juice pump pumps the juice to the tanks.
- Air compressor and high pressure washer is included.
- Pump is integrated.
- Adjustable belt tension.
- Easy to clean with no closed or inaccessible spaces, all parts are easy to assemble.
- Automatic cleaning of belt with high pressure cleaner, scraper and brush.
- Pneumatic lifting of the security cover of the press for easier access when cleaning.

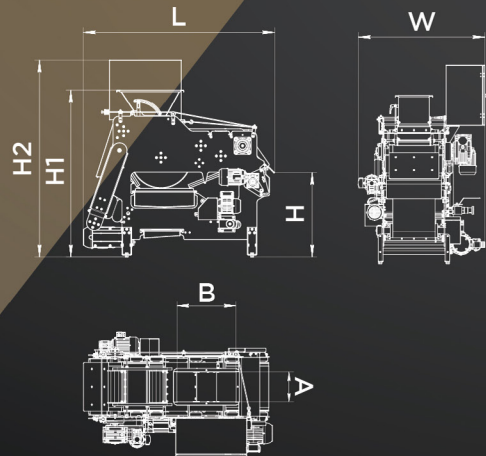
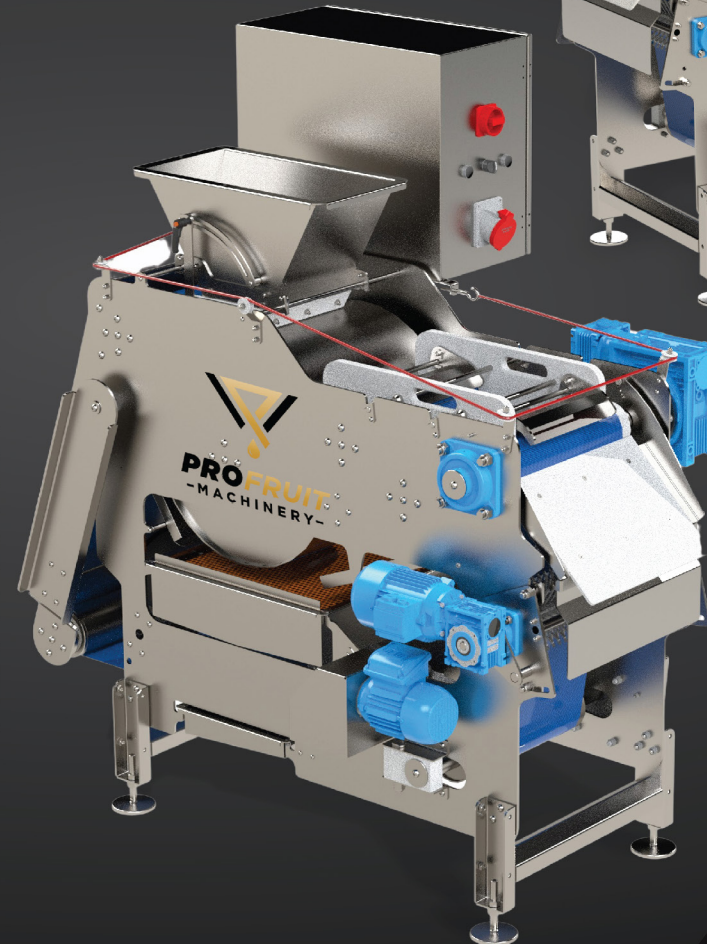
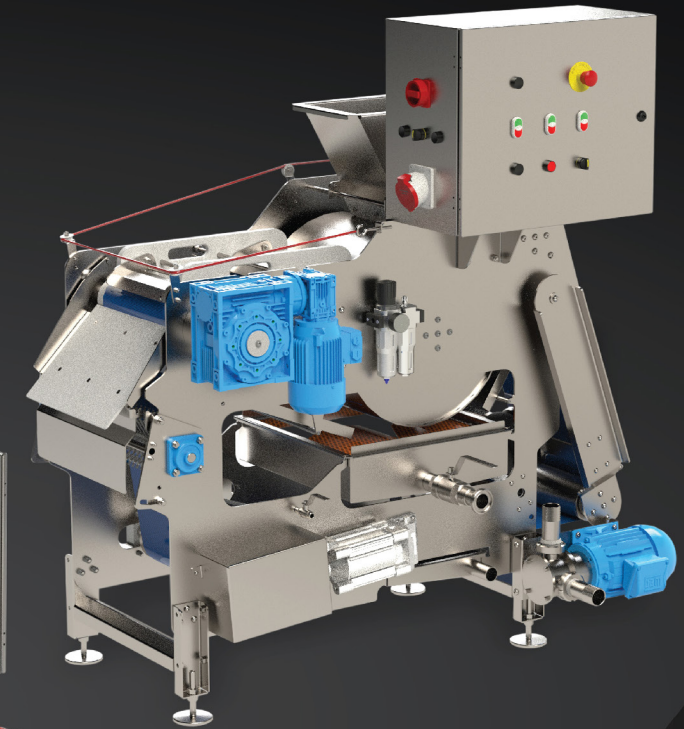
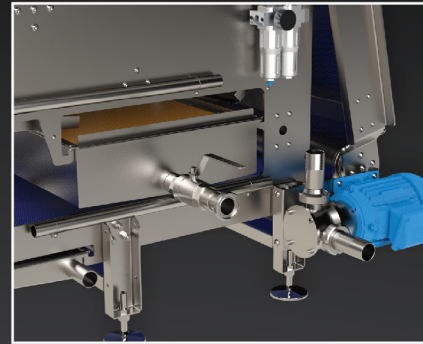

Capacity	kg/h	350
L	mm	1600
W	mm	1050
H	mm	750
H1	mm	1440
H2	mm	1690
A x B	mm	250x500
Weight	kg	360
Power source1	kW	0,12
Power source2	kW	0,37
Power source3	kW	0,37



PROFRUIT
-MACHINERY-